

# LTE router LR77 v2

## USER'S MANUAL



## Used Symbols



*Danger* – important notice, which may have an influence on the user's safety or the function of the device.



*Attention* – notice on possible problems, which can arise in specific cases.



*Information, notice* – information, which contains useful advice or special interest.

## GPL License

Source codes under GPL license are available free of charge by sending an email to:

[info@conel.cz](mailto:info@conel.cz).



# Contents

<b>1</b>	<b>Safety Instruction</b>	<b>1</b>
<b>2</b>	<b>Product Disposal Instructions</b>	<b>2</b>
<b>3</b>	<b>Router description</b>	<b>3</b>
<b>4</b>	<b>Contents of package</b>	<b>4</b>
<b>5</b>	<b>Router design</b>	<b>5</b>
5.1	Router versions . . . . .	5
5.2	Delivery identification . . . . .	6
5.3	Ordering codes . . . . .	6
5.3.1	Basic version . . . . .	6
5.3.2	Full version . . . . .	7
5.4	Basic dimensions of plastic box . . . . .	8
5.5	Basic dimensions of metal box . . . . .	8
5.6	Mechanical dimensions and mounting recommendations . . . . .	9
5.7	Removing from the DIN rail . . . . .	11
5.8	Description of the front panel . . . . .	12
5.8.1	Status indication . . . . .	13
5.8.2	Power connector PWR . . . . .	14
5.8.3	Antenna connector ANT, DIV and GPS (alternatively WIFI or WMBUS) . . . . .	15
5.8.4	SIM card reader . . . . .	16
5.8.5	Ethernet port . . . . .	16
5.8.6	PORT1 . . . . .	18
5.8.7	PORT2 . . . . .	18
5.8.8	USB Port . . . . .	19
5.8.9	I/O Port . . . . .	20
5.8.10	Reset . . . . .	22
<b>6</b>	<b>First use</b>	<b>23</b>
6.1	Connecting the router before first use . . . . .	23
6.2	Start . . . . .	24
6.3	Configuration . . . . .	24
6.3.1	Configuration over web browser . . . . .	24
6.3.2	Configuration over Telnet . . . . .	24
<b>7</b>	<b>Technical parameters</b>	<b>25</b>

7.1	Technical parameters of router . . . . .	25
7.2	Technical parameters of module . . . . .	26
7.2.1	Versions LR77 v2B and LR77 v2F . . . . .	26
7.2.2	Versions LR77 v2BG and LR77 v2FG . . . . .	26
7.3	Technical parameters of GPS . . . . .	27
7.4	Technical parameters of processor . . . . .	28
7.5	Technical parameters I/O port . . . . .	28
7.6	Technical parameters of expansion port . . . . .	28
<b>8</b>	<b>Recommended literature</b>	<b>29</b>
<b>9</b>	<b>Possible problems</b>	<b>30</b>
<b>10</b>	<b>FAQ</b>	<b>31</b>
<b>11</b>	<b>Customers Support</b>	<b>33</b>

# List of Figures

1	Contents of package . . . . .	4
2	Front panel LR77 v2B(G) . . . . .	5
3	Front panel LR77 v2F(G) . . . . .	5
4	Front panel LR77 v2B(G) SL . . . . .	5
5	Front panel LR77 v2F(G) SL . . . . .	5
6	Label LR77 v2B . . . . .	6
7	Label LR77 v2B SL . . . . .	6
8	Label LR77 v2F . . . . .	6
9	Label LR77 v2F SL . . . . .	6
10	Basic dimensions of plastic box . . . . .	8
11	Basic dimensions of metal box . . . . .	8
12	Space around antennas . . . . .	9
13	Space around antennas for SL . . . . .	9
14	Cable routing . . . . .	10
15	Cable routing for SL version . . . . .	10
16	Space in front of connectors . . . . .	10
17	Space in front of connectors – SL . . . . .	10
18	Default position of DIN holder . . . . .	11
19	Removing from the DIN rail . . . . .	11
20	Front panel LR77 v2F(G) SL . . . . .	12
21	Power connector . . . . .	14
22	Connection of power supply connector . . . . .	14
23	Connection of power supply . . . . .	14
24	External antenna . . . . .	15
25	Connecting of the antenna . . . . .	15
26	Ejected SIM holder . . . . .	16
27	Ethernet connector . . . . .	17
28	Connection of ethernet cable . . . . .	17
29	Example of router connection . . . . .	17
30	PORT1 cable connection . . . . .	18
31	PORT2 cable connection . . . . .	19
32	USB connector . . . . .	19
33	Connection PLC to the router . . . . .	20
34	Connection flash memory to the router . . . . .	20
35	I/O connector . . . . .	20
36	Connection of I/O cable . . . . .	21
37	Connection of input and output to the router . . . . .	21
38	Router reset . . . . .	22
39	Router connection . . . . .	23

# List of Tables

1	Router versions . . . . .	5
2	Delivery identification . . . . .	6
3	Ordering codes of basic version . . . . .	6
4	Ordering codes of full version . . . . .	7
5	Front panel description . . . . .	12
6	Router status indication . . . . .	13
7	Connection of power connector . . . . .	14
8	Connection of Ethernet connector . . . . .	16
9	Connection of USB connector . . . . .	19
10	Connection of I/O port . . . . .	20
11	Description of reset and restart router . . . . .	22
12	Technical parameters of router . . . . .	25
13	Technical parameters of module . . . . .	26
14	Technical parameters of module . . . . .	27
15	Technical parameters of GPS . . . . .	27
16	Technical parameters of processor . . . . .	28
17	Technical parameters I/O port . . . . .	28

# 1. Safety Instruction



***Please, observe the following instructions:***

- The router must be used in compliance with all applicable international and national laws and in compliance with any special restrictions regulating the utilization of the router in prescribed applications and environments.
- To prevent possible injury to health and damage to appliances and to ensure that all the relevant provisions have been complied with, use only the original accessories. Unauthorised modifications or utilization of accessories that have not been approved may result in damage to the router and in a breach of applicable regulations. Unauthorized modifications or utilization of accessories that have not been approved may result in the termination of the validity of the guarantee.
- The router can not be opened.
- Before handling of the SIM card turn off the router and disconnect it from power supply.



- **Caution!** The SIM card could be swallowed by small children.
- It must not be exceeded by the maximum voltage 30 V DC power connector on the router.
- Do not expose the router to extreme ambient conditions. Protect the router against dust, moisture and high temperature.
- The router should not be used at petrol stations of flammable and explosive materials. We remind the users of the duty to observe the restrictions concerning the utilization of radio devices at petrol stations, in chemical plants, or in the course of blasting works in which explosives are used.
- Switch off the router when travelling by plane. Utilization of the router in a plane may endanger the operation of the plane or interfere with the mobile telephone network, and may be unlawful. Failure to observe these instructions may result in the suspension or cancellation of telephone services for the respective client, or, it may result in legal sanctions; it may also result in both eventualities.
- When using the router in the close proximity of personal medical devices, such as cardiac pacemakers or hearing aids, you must proceed with heightened caution.
- If it is in the proximity of TV sets, radio receivers and personal computers, the telephone may cause interference.
- It is recommended that you should create an appropriate copy or backup of all the important settings that are stored in the memory of the device.

## 2. Product Disposal Instructions

The WEEE (Waste Electrical and Electronic Equipment: 2002/96/EC) directive has been introduced to ensure that electrical/electronic products are recycled using the best available recovery techniques to minimize the impact on the environment. This product contains high quality materials and components which can be recycled. At the end of it's life this product **MUST NOT** be mixed with other commercial waste for disposal. Check the terms and conditions of your supplier for disposal information.



## 3. Router description

LTE router LR77 v is used to wirelessly connect various equipments and devices via Ethernet interface 10/100 to the Internet or Intranet. Thanks to high data transfer speed of up to 100 Mbit/s (download) and upload speed up to 50 Mbit/s it is an ideal wireless solution for traffic and security camera systems, individual computers, LAN networks, automatic teller machines (ATM) and other self-service terminals, etc.

As a standard, this exceptionally fast LTE LR77 v2 wireless router is equipped with one Ethernet 10/100, one USB Host port, one binary Input/output (I/O) port and one SIM card. To save and backup communication data a version with two SIM cards is available. The wide range of interface options of the router further expands Port1 and Port2 expansion ports, which are selected by the customer. For Port1 are available: Ethernet port 10/100, serial interface ports RS232/RS485/RS422/MBUS or inputs/outputs (I/O – CNT). Port2 may be equipped with serial interfaces RS232/RS485/RS422/MBUS, wireless interfaces WIFI/WMBUS, SDH expansion port or inputs/outputs (I/O – CNT). Both of ports can be fitted with internal switch (exp. port SWITCH). This wireless router is supplied either in a plastic or metal casing, based on the requirements of the customer.

Configuration is done via web interface protected by password. The LR77 v2 router supports creation of VPN tunnels using technologies IPsec, OpenVPN and L2TP to ensure safe communication. Web interface provides detail statistics about the router activities, signal strength, detailed log, etc. Cellular router supports functions: DHCP, NAT, NAT-T, DynDNS, NTP, VRRP, control by SMS and many other function.

Other diagnostic functions ensuring continuous communication include automatic inspection of PPP connection offering an automatic restart feature – in case of connection losses, or hardware watchdog which monitors the status of the router. With the help of a special window (start up script window) you may insert Linux scripts for various actions. For some applications the key option to create several different configurations for one LTE wireless router, the so-called profiles (maximum of 4), and the option to switch between them (for example via SMS, binary input status, etc.) is essential. Cellular wireless routers LR77 v2 may automatically upgrade configuration and firmware from server. This allows mass reconfiguration of many routers in one time.

For easy use additional software may be used – communication VPN server Digicluster and software for router monitoring R-SeeNet.



### Examples of possible applications

- mobile office
- fleet management
- security system
- telematic
- telemetric
- remote monitoring
- vending and dispatcher machines

## 4. Contents of package



Basic delivered set of router includes:

- router,
- power supply,
- crossover UTP cable,
- two external antennas,
- clip for the DIN rail,
- installation CD containing instructions,
- paper start guide.



Figure 1: Contents of package



The router can also be supplied as expansion accessories:

- One (Basic version) or two (Full version) expansion ports: RS232, RS485/422, MBUS, ETHERNET, CNT, SWITCH, WIFI, WMBUS or SDH. Separation columns for mounting expansion boards are included.

# 5. Router design

## 5.1 Router versions

LR77 v2 router is supplied in the following versions:

Version	Router Box	SIM1	SIM2	I/O	USB	PORT1	PORT2	ETH
LR77 v2B(G)	Plastic	1 x		1 x	1 x	1 x		1 x
LR77 v2B(G) SL	Matel	1 x		1 x	1 x	1 x		1 x
LR77 v2F(G)	Plastic	1 x	1 x	1 x	1 x	1 x	1 x	1 x
LR77 v2F(G) SL	Metal	1 x	1 x	1 x	1 x	1 x	1 x	1 x

Table 1: Router versions



Figure 2: Front panel LR77 v2B(G)



Figure 4: Front panel LR77 v2B(G) SL



Figure 3: Front panel LR77 v2F(G)

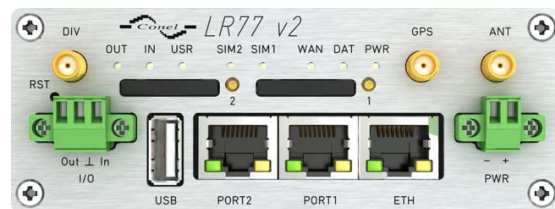

Figure 5: Front panel LR77 v2F(G) SL

## 5.2 Delivery identification

Trade name	Type name	Other
LR77 v2B(G)	LR-77-v2	Basic version
LR77 v2B(G) SL	LR-77-v2	Basic version in the metal box
LR77 v2F(G)	LR-77-v2	Full version
LR77 v2F(G) SL	LR-77-v2	Full version in the metal box

Table 2: Delivery identification



Figure 6: Label LR77 v2B



Figure 8: Label LR77 v2F



Figure 7: Label LR77 v2B SL



Figure 9: Label LR77 v2F SL

## 5.3 Ordering codes

### 5.3.1 Basic version

Expansion port	Ordering code
Version without expansion port	LR77 v2B(G) set
Version with Ethernet expansion port	LR77 v2B(G) ETH set
Version with RS232 expansion port	LR77 v2B(G) RS232 set
Version with RS485 expansion port	LR77 v2B(G) RS458 set
Version with MBUS expansion port	LR77 v2B(G) MBUS set
Version with CNT expansion port	LR77 v2B(G) CNT set

Table 3: Ordering codes of basic version

## 5.3.2 Full version

Expansion port	Participation	Ordering code
Version without expansion port		LR77 v2F set
Version with Ethernet expansion port	PORT1	LR77 v2F(G) ETH set
Version with RS232 expansion port	PORT1 a PORT2	LR77 v2F(G) RS232 set
Version with RS485 expansion port	PORT1 a PORT2	LR77 v2F(G) RS458 set
Version with MBUS expansion port	PORT1 a PORT2	LR77 v2F(G) MBUS set
Version with CNT expansion port	PORT1	LR77 v2F(G) CNT set
Version with SWITCH expansion port	PORT1 + PORT2	LR77 v2F(G) SWITCH set
Version with WIFI expansion port	PORT2	LR77 v2F(G) WIFI set
Version with WMBUS expansion port	PORT2	LR77 v2F(G) WMBUS set
Version with SDH expansion port	PORT2	LR77 v2F(G) SDH set

Table 4: Ordering codes of full version

Second expansion port is written after first expansion port in the ordering code.

Example:

- Full version with Ethernet and RS232 port: **LR77 v2F ETH RS232 set.**
- Full version with Ethernet and RS232 port in metal cover: **LR77 v2F ETH RS232 SL set.**

If you want to have a router with WIFI (or WMBUS) and GPS instead of diversity, use the ordering code in this form: **LR77 v2F(G)3**. WIFI connector is reverse as a standard (WMBUS connector is classic SMA as a standard). If you want a classic SMA connector (reverse SMA in case of WMBUS) use **LR77 v2F(G)4** for version with diversity antenna and **LR77 v2F(G)5** for version with GPS (i.e. no diversity).

### 5.4 Basic dimensions of plastic box

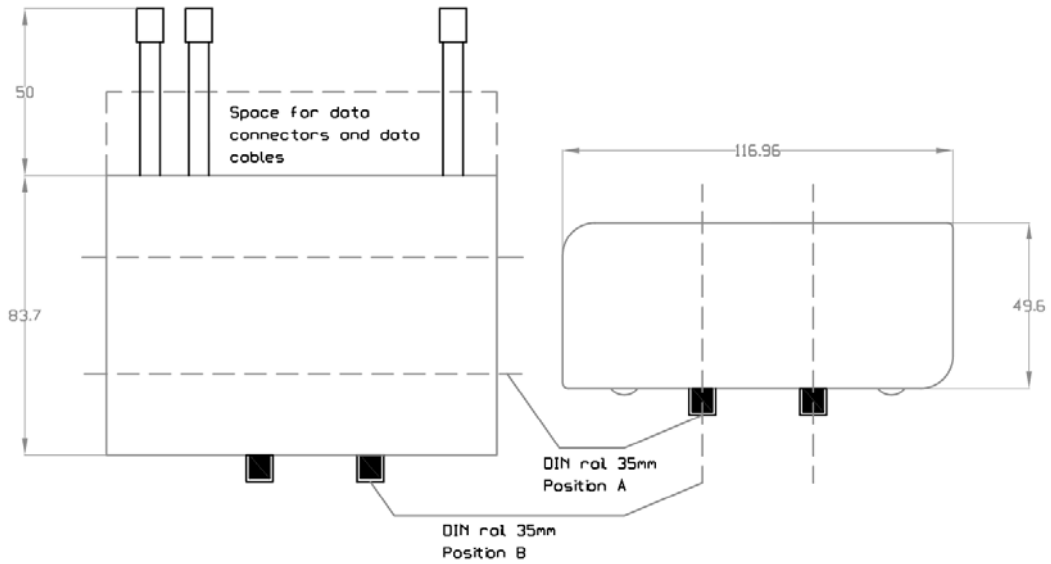

Figure 10: Basic dimensions of plastic box

### 5.5 Basic dimensions of metal box

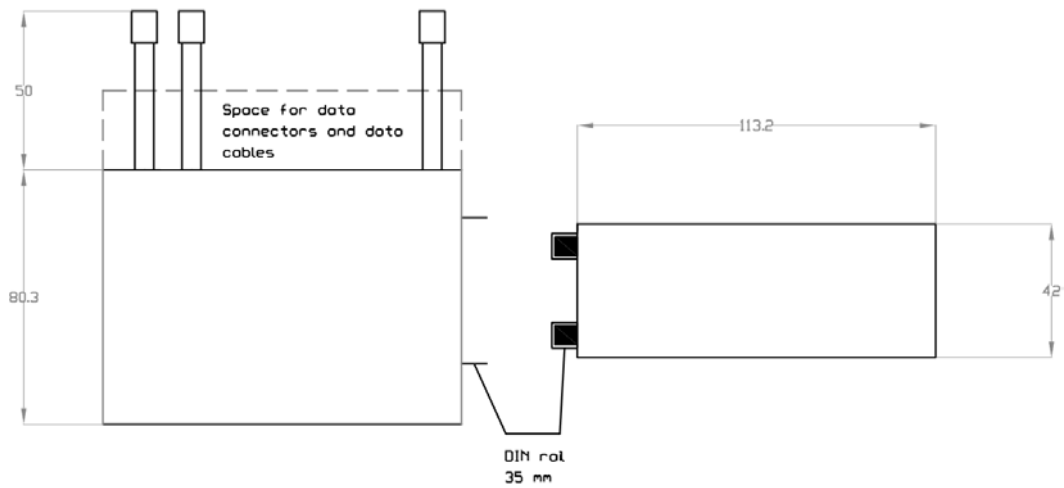

Figure 11: Basic dimensions of metal box

## 5.6 Mechanical dimensions and mounting recommendations



Mounting recommendations:

- possibility to be put on a work surface,
- DIN rail with clips CKD2 (ELPAC clip SL for metal version) are included.

For the most of applications with a built-in router in a switch board it is possible to recognize two kinds of environments:

- no public and industry environment of low voltage with high interference,
- public environment of low voltage without high interference.

For both of these environments it is possible to mount router to a switch board, the following there is no need to have examination immunity or issues in connection with EMC according to EN 60439-1 ed.2:00 + A1:04.

For compliance of EN 60439-1 ed.2:00 + A1:04 specification it is necessary to observe next assembly of the router to the switch – board:



- for whip antennas we recommend to observe a distance of 6 cm from cables and metal surfaces on every side according to the next picture due to the elimination of interference, while using an external antenna except for the switch-board it is necessary to fit a lightening conductor,



- before mounting a router on sheet-steel we recommend using an external antenna,

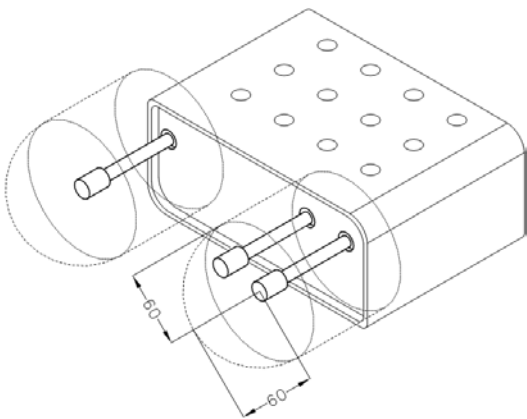

Figure 12: Space around antennas

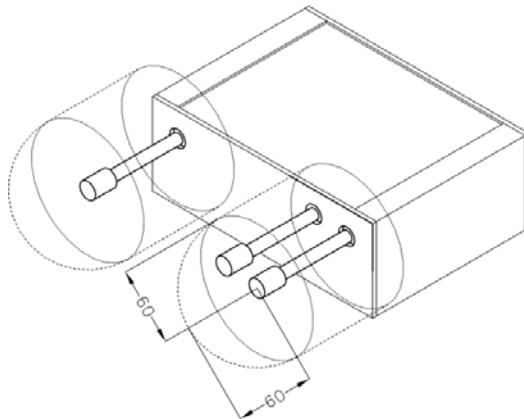

Figure 13: Space around antennas for SL



- For every cables we recommend to bind the bunch according to the following picture, we recommend for this use:
  - Length of the bunch (combination of power supply and data cables) can be maximum 1,5 m. If the length of data cables exceeds 1,5 m or in the event of, the cable leads towards the switch – board. We recommend installing over – voltage protectors (surge suppressors).
  - With data cables they mustn't carry cables with reticular tension  $\sim 230\text{ V}/50\text{ Hz}$ .
  - All signals to sensors must be twisted pairs.

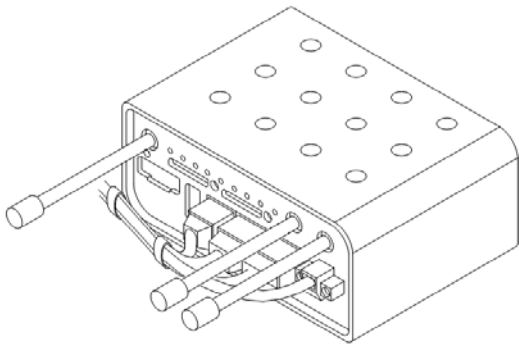

Figure 14: Cable routing

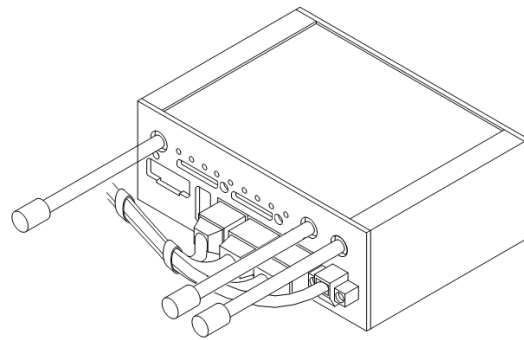

Figure 15: Cable routing for SL version



- Sufficient space must be left before individual connectors for handling of cables,

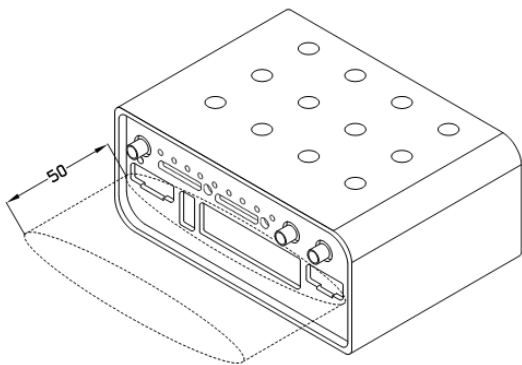

Figure 16: Space in front of connectors

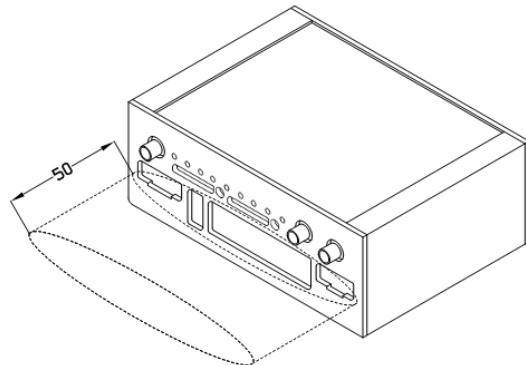

Figure 17: Space in front of connectors – SL



- For correct function of the router we recommend to use in the switch-board earth-bonding distribution frame for grounding of power supply of router, data cables and antenna.



### 5.7 Removing from the DIN rail

Default position of CPD2 holder (or CKD2 holder for SL version), which is used for mounting the router on a DIN rail, is shown in the following figure:

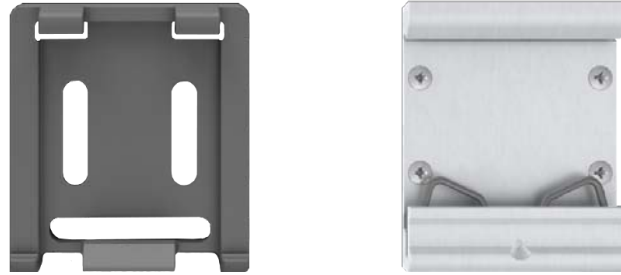

Figure 18: Default position of DIN holder

For removing from the DIN rail it is necessary to lightly push upward the router so that the top part of the CPD2 holder (or CKD2 for SL version) hitched to the DIN rail get out of this rail and then fold out the top part of the router away from the DIN rail.

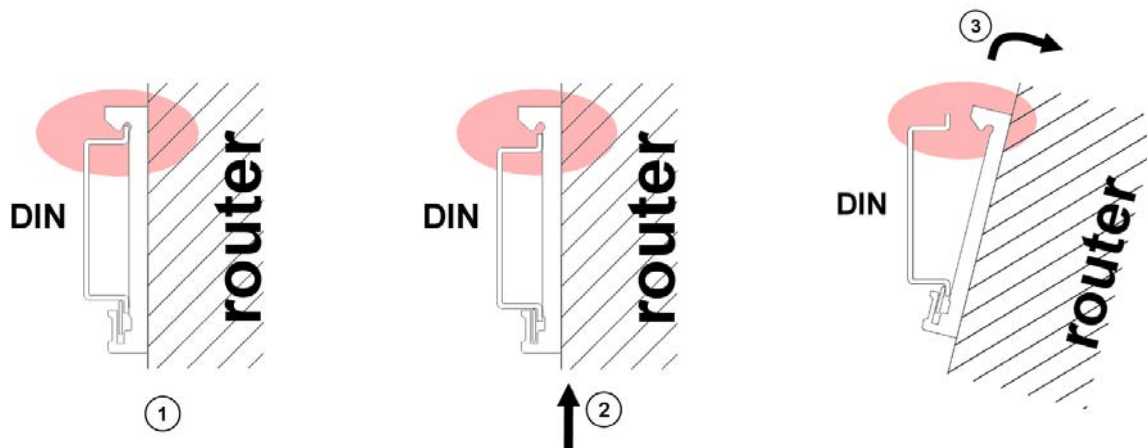

Figure 19: Removing from the DIN rail

## 5.8 Description of the front panel

On the front panel is located:

Caption	Connector	Description
PWR	2-pin	Connector for the power supply adapter.
ETH	RJ45	Connector for connection into the local computer network.
PORT1	RJ45	Connector for expansion port RS232, RS458/422, MBUS, ETHERNET, CNT or SWITCH.
PORT2	RJ45	Connector for expansion port RS232, RS485/422, MBUS, SWITCH, WIFI, WMBUS or SDH (only FULL version).
ANT	SMA	Connector for main antenna.
DIV	SMA	Connector for diversity antenna.
GPS	SMA	Connector for GPS antenna. It can be replaced with connector for WIFI or WMBUS antenna.
WIFI	R-SMA	Connector for WIFI antenna. <b>Only when router is equipped with an expansion port WIFI.</b>
WMBUS	SMA	Connector for WMBUS antenna. <b>Only when it is equipped with an expansion port WMBUS.</b>
USB	USB-A Host	Connector for connection of USB devices to the router. Supports devices with PL-2303 and FTDI USB/RS232 converters.
I/O	3-pin	Connector for connection of the binary input and output.
SIM1	—	Holder for the first SIM card.
SIM2	—	Holder for the second SIM card (only FULL version).

Table 5: Front panel description

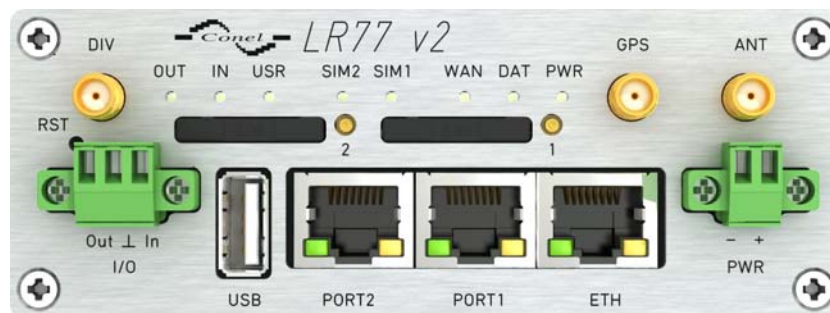

Figure 20: Front panel LR77 v2F(G) SL

### 5.8.1 Status indication

About router status inform eight led indicators on the front panel and on every port are two LED indicators, which inform about port status.

Caption	Color	State	Description
PWR	Green	Blinking On Fast blinking	Router is ready Starting of the router Updating firmware
DAT	Red	Blinking	Communication in progress on radio channel
WAN	Yellow	1x flash per second 2x flash per second  3x flash per second	Signal strength is from -50 dBm to -69 dBm Signal strength is from -70 dBm to -89 dBm or difference between neighbours cells is exactly 3 dBm Signal strength is from -90 dBm to -113 dBm or difference between neighbours cells is smaller than 3 dBm
USR	Yellow	Function selected by user	
OUT	Green	On	Binary output active
IN	Green	On	Binary input active
ETH	Green	On Off	Selected 100 Mbit/s Selected 10 Mbit/s
ETH	Yellow	On Blinking Off	The network cable is connected Data transmission The network cable is not connected
PORT	Green	Depends on the expansion port (see user's guide of used port)	
PORT	Yellow	Depends on the expansion port (see user's guide of used port)	
SIM1	Yellow	On	SIM card 1 is active
SIM2	Yellow	On	SIM card 2 is active

Table 6: Router status indication



State indication of WAN LED is updated every 10 seconds.

### 5.8.2 Power connector PWR

Panel socket 2-pin.

Pin number	Signal mark	Description
1	VCC(+)	Positive pole of DC supply voltage (+10 to +30 V DC)
2	GND(-)	Negative pole of DC supply voltage

Table 7: Connection of power connector

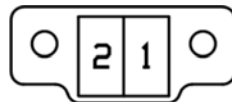

Figure 21: Power connector

Power supply for router is required between +10 V to +30 V DC supply. Protection against reversed polarity without signaling is built into the router.

The power consumption during receiving is 2,3 W. The peak power consumption during data sending is 5,5 W. However, values of consumption can be increased, if some expansion port is equipped. For correct operation it is necessary that the power source is able to supply a peak current of 1 A.



Connector on the power cable connects into the power connector on the router head and tightens locking screws (see figure below).

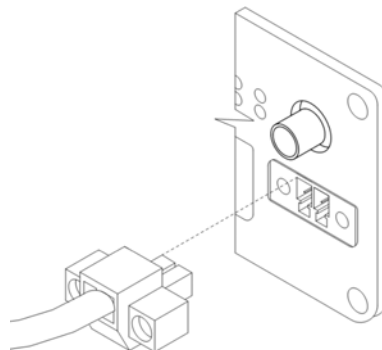

Figure 22: Connection of power supply connector



Circuit example:

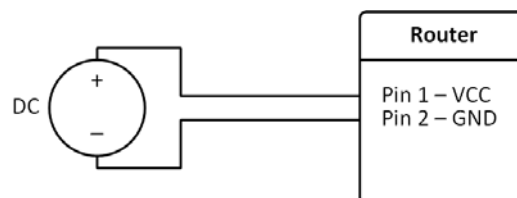

Figure 23: Connection of power supply



The positive pole VCC is marked by a red socket on the power.

### 5.8.3 Antenna connector ANT, DIV and GPS (alternatively WIFI or WMBUS)

Main and diversity antennas are connected to the router using the SMA connector on the front panel. In the Full version of the router is also available the third SMA antenna connector, through which the additional antenna can be connected (in case of the WIFI expansion port is used, this connector is reverse – RSMA).



The router can not operate without connecting the main antenna marked as ANT.

ANT connector is used to connect the main antenna router. To connect the diversity antenna is used the second antenna connector DIV. The third connector (GPS) in the full version of the router is used for additional antenna intended for GPS (router supports active GPS antenna). On user's request, this antenna connector can be modified to WIFI or WMBUS.



Example of antenna:

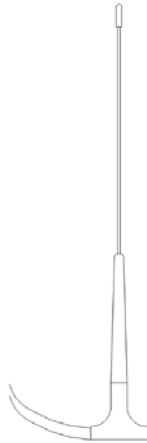

Figure 24: External antenna



For connection the antenna is used SMA connector. The antenna is connected by screwing this antenna to the SMA connector on the front panel of the router (see figure below).

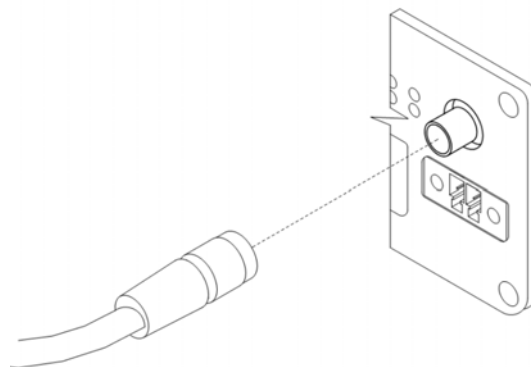

Figure 25: Connecting of the antenna



Diversity antenna improves radio features of the router at low signal strength.

### 5.8.4 SIM card reader

The SIM card reader for 3 V and 1,8 V SIM cards is located on the front panel of the router. To initiate the router into operation it is necessary to insert an activated SIM card with unblocked PIN in the reader. The SIM cards might be of different adjusted APN (Access Point Name).

#### Changing the SIM card:



Before handling of the SIM card turn off the router and disconnect it from power supply.

Press the small yellow button to eject the reader holder. Insert the SIM card into the reader holder and slide it in the reader (see figure below).

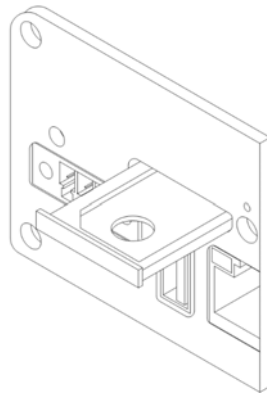

Figure 26: Ejected SIM holder

### 5.8.5 Ethernet port

Panel socket RJ45.

Pin	Signal mark	Description	Data flow direction
1	TXD+	Transmit Data – positive pole	Input/Output
2	TXD-	Transmit Data – negative pole	Input/Output
3	RXD+	Receive Data – positive pole	Input/Output
4	—	—	
5	—	—	
6	RXD-	Receive Data – negative pole	Input/Output
7	—	—	
8	—	—	

Table 8: Connection of Ethernet connector

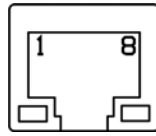

Figure 27: Ethernet connector



**ATTENTION! Port ETH is not POE (Power Over Ethernet) compatible!**

Ethernet cable plug into the RJ45 connector labeled as ETH (see figure below).

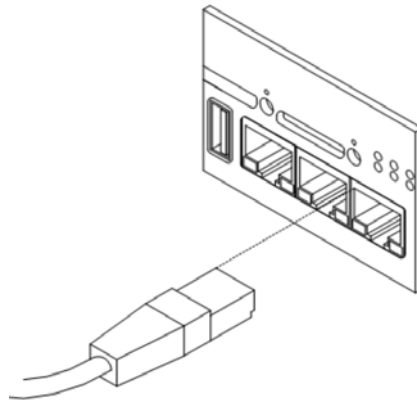

Figure 28: Connection of ethernet cable



Example of the ETH router connection:

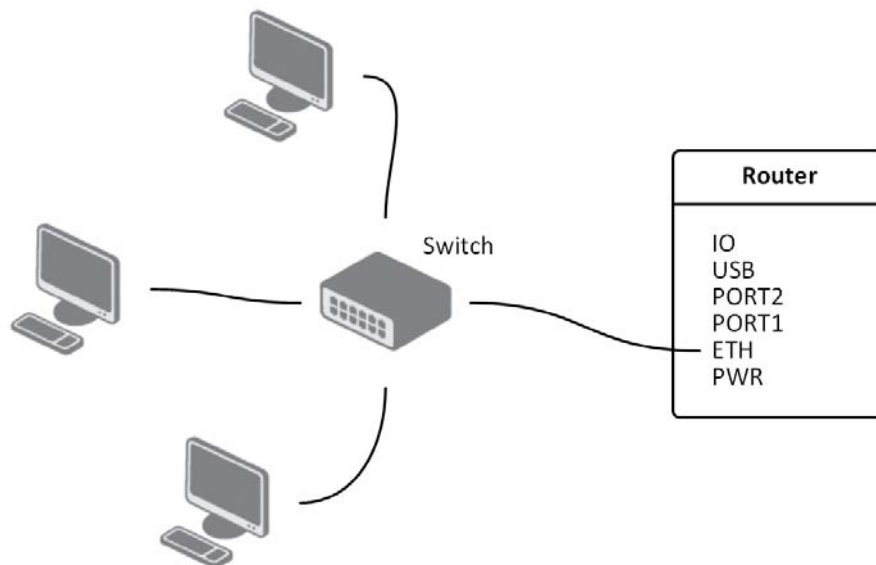

Figure 29: Example of router connection

### 5.8.6 PORT1

The PORT1 is equipped on customer's request with one of the offered expansion ports:

- RS232
- RS485
- RS422
- ETHERNET
- MBUS
- CNT
- SWITCH (together with PORT2)



Description and examples of expansion ports connection can be found in user's guide for corresponding expansion port.

PORT1 cable plug into the RJ45 connector labeled as PORT1 (see figure below).

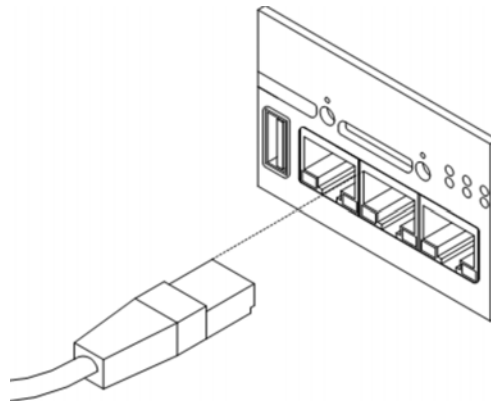

Figure 30: PORT1 cable connection

### 5.8.7 PORT2

The PORT2 is equipped on customer's request with one of the offered expansion ports:

- RS232
- RS485
- RS422
- MBUS
- SDH
- SWITCH (together with PORT1)
- WIFI
- WMBUS



PORT2 is available only in the Full version of the router! Description and examples of expansion ports connection can be found in user's guide for corresponding expansion port.



PORT2 cable plug into the RJ45 connector labeled as PORT1 (see figure below).

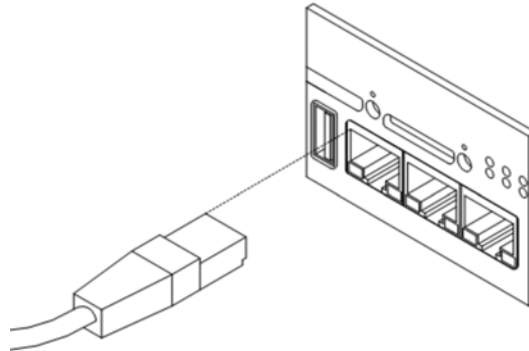

Figure 31: PORT2 cable connection

### 5.8.8 USB Port

Panel socket USB-A.

Pin	Signal mark	Description	Data flow direction
1	+5 V	Positive pole of 5 V DC supply voltage	
2	USB data -	USB data signal – negative pole	Input/Output
3	USB data +	USB data signal – positive pole	Input/Output
4	GND	Negative pole of DC supply voltage	

Table 9: Connection of USB connector



Figure 32: USB connector



Example of connecting devices with serial interface to the USB:

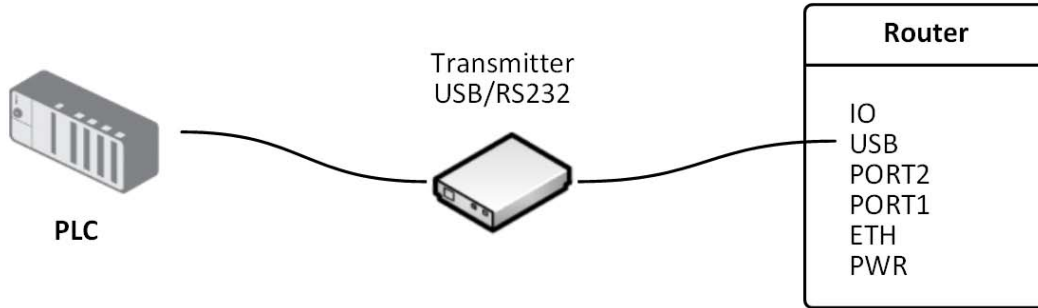

Figure 33: Connection PLC to the router



Example of connecting of USB flash disk to the USB:

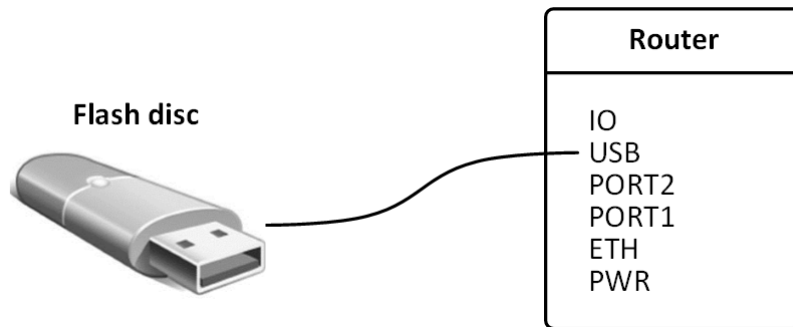

Figure 34: Connection flash memory to the router

### 5.8.9 I/O Port

Panel socket 3pin.

Pin	Signal mark	Description	Data flow direction
1	BIN0	Binary input	Input
2	GND	Signálová zem	
3	OUT0	Binary output	Output

Table 10: Connection of I/O port

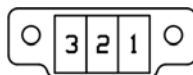

Figure 35: I/O connector

The user interface I/O is for processing of binary input signal and to control (settings) of binary output signal. Binary output is not switched to ground in the default configuration.

Maximum load binary output is 30 V / 100 mA. The constant current supplied by the binary input is 3 mA.

Connector I/O cable connect into the I/O connector on the router head and tighten locking screws (see figure below).

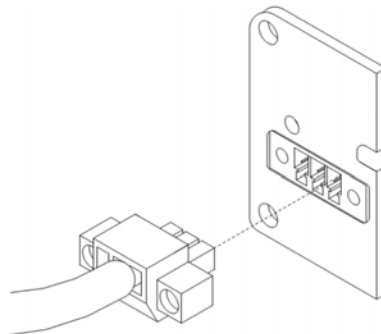

Figure 36: Connection of I/O cable

Circuit example of a binary input or output equipment with router:

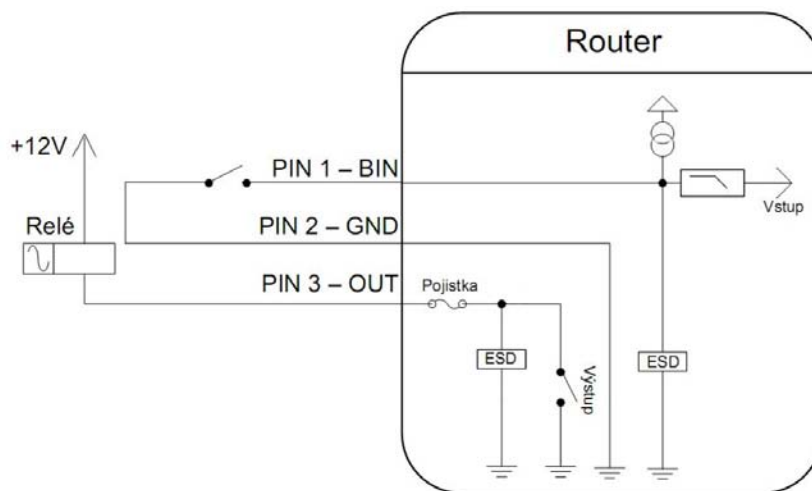

Figure 37: Connection of input and output to the router

### 5.8.10 Reset



It is important to distinguish between reset and reboot the router.

Action	Router behavior	Invoking events
Reboot	Turn off and then turn on router	Disconnect and connect the power, Press the <i>Reboot</i> button in the web configuration
Reset	Restore default configuration and reboot the router	Press RST button

Table 11: Description of reset and restart router

After green LED starts to blink it is possible to restore initial settings of the router by pressing button RST on front panel. After press button RST it is restoration of default configuration and reboot (green LED will be on).



For pressing the RST button could be used a narrow screwdriver.

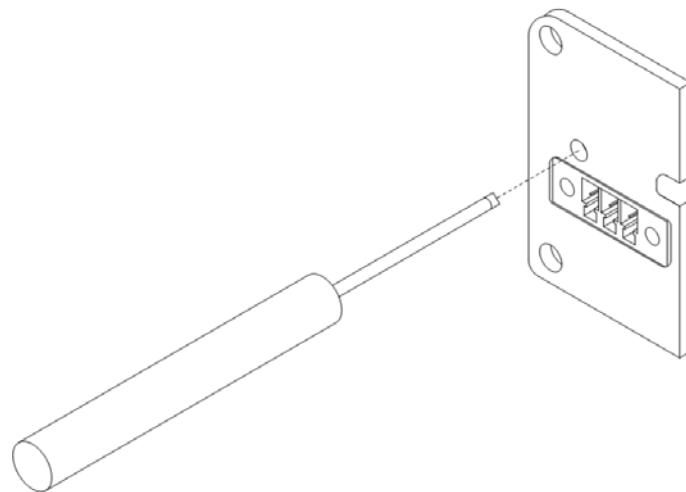

Figure 38: Router reset



We recommend to backup your router configuration (see Configuration manual), because after reset router set configuration to the initial state.

# 6. First use

## 6.1 Connecting the router before first use

Before you give up the router, it is necessary to connect all components needed for the operation of your applications and the SIM card must be inserted (see figure below).



The router can not operate without connected antenna, SIM card and power supply. If the antenna is not connected, router can be damaged.

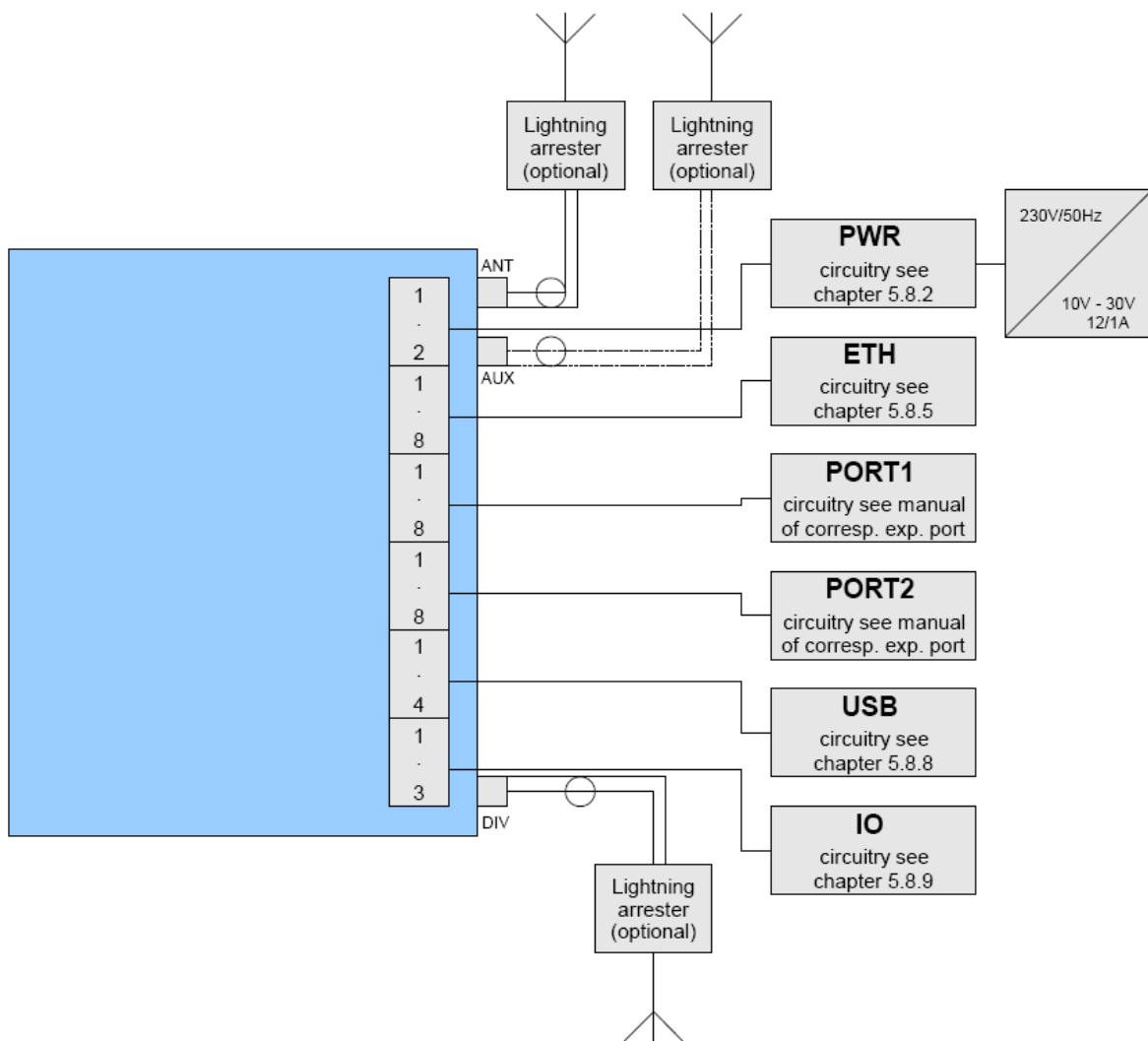

Figure 39: Router connection

## 6.2 Start

The router is set up connecting the power supply to the router. In the default setting the router starts to login automatically to the preset APN. Device on the Ethernet port DHCP server will assign addresses. The behavior of the router can be modified by means of the web or Telnet interface, which is described in the configuration manual.

The power consumption during receiving is 2,3 W. The peak power consumption during data sending is 5,5 W. However, values of consumption can be increased, if some expansion port is equipped. For correct operation it is necessary that the power source is able to supply a peak current of 1 A.

## 6.3 Configuration



**Attention!** If the SIM card is not inserted in the router, then it is impossible to operate. The inserted SIM card must have activated LTE, HSPA+, UMTS, EDGE or GPRS.

### 6.3.1 Configuration over web browser

Monitoring of the status, configuration and administration of the router can be performed by means of the web interface, which is available after insertion of IP address of the router into the web browser. The default IP address of the router is 192.168.1.1. Configuration may be performed only by the user "root" with initial password "root".



A detailed description of the router settings via the Web interface can be found in the *Configuration manual for v2 routers*.

### 6.3.2 Configuration over Telnet

Monitoring of status, configuration and administration of the router can be performed by means of the Telnet interface. After IP address entry to the Telnet interface it is possible to configure the router by the help of commands. The default IP address of the router is 192.168.1.1. Configuration may be performed only by the user "root" with initial password "root".



A detailed description of the router settings via the Telnet interface can be found in the *Configuration manual v2 routers*.

# 7. Technical parameters

## 7.1 Technical parameters of router

LR77 v2		
Complies with standards		EN 301 511, v9.0.2, EN 301 908-1 & -2: v5.2.1, ETSI EN 301 489-1 v1.9.2, EN 60950-1:2006 + A11:2009 + A1:2010 + A12:2011 + AC:2011 + A2:2013
Temperature range	Function Storage	-40 °C to +75 °C -40 °C to +85 °C
Protection		IP20
Supply voltage		10 to 30 V DC
Consumption	Reception GPRS LTE	2,3 W to 3,5 W (GPRS transmission) to 5,5 W (LTE transmission)
Dimensions	Plastic box Metal box	51 x 87 x 116 mm (DIN 35 mm) 42 x 87 x 113 mm (DIN 35 mm)
Weight		LR77 v2 – 150 g LR77 v2 SL – 280 g
Antenna connector		3x SMA – 50 Ohm
User interface	ETH USB PORT1 PORT2	Ethernet (10/100 Mbit/s) USB 2.0 On customer's request On customer's request

Table 12: Technical parameters of router

## 7.2 Technical parameters of module

### 7.2.1 Versions LR77 v2B and LR77 v2F

<b>LTE module</b>	
LTE parameters	Bit rate 100 Mbps (DL) / 50 Mbps (UL) 3GPP rel. 8 standard Supported bandwidth: 5 Mhz, 10 Mhz, 20 Mhz
HSPA+ parameters	Bit rate 21,1 Mbps (DL) / 5,76 Mbps (UL) 3GPP rel. 7 standard UE CAT. 1 to 6, 8, 10, 12, 14 3GPP data compress
UMTS parameters	PS bit rate 384 kbps (DL) / 384 kbps (UL) CS bit rate 64 kbps (DL) / 64 kbps (UL) W-CDMA FDD standard
GPRS/EDGE parameters	Bit rate 237 kbps (DL) / 59,2 kbps (UL) GPRS multislots class 10, CS 1 to 4 EDGE multislots class 12, CS 1 to 4, MCS 1 to 9
Supported GPRS/EDGE power classes	EGSM 900: Class 4 (33 dBm) GSM 1800/1900: Class 1 (30 dBm) EDGE 900: Class E2 (27 dBm) EDGE 1800/1900: Class E2 (26 dBm)
Supported channels	GSM/GPRS/EDGE: 850/900/1800/1900 MHz UMTS/HSDPA/HSUPA/HSPA+: 850/900/1900/2100 MHz LTE: 800/900/1800/2100/2600 Mhz

Table 13: Technical parameters of module

### 7.2.2 Versions LR77 v2BG and LR77 v2FG

<b>LTE modul</b>	
LTE parameters	Bit rate 100 Mbps (DL) / 50 Mbps (UL) 3GPP rel. 8 standard Supported bandwidths: 5 Mhz, 10 Mhz, 20 Mhz
HSPA+ parameters	Bit rate 42 Mbps (DL) / 5,76 Mbps (UL) 3GPP rel. 6/7 standard Data compress 3GPP
UMTS parameters	Bit rate 384 kbps (DL) / 384 kbps (UL) 3GPP rel. 4 standard

Continued on next page



Continued from previous page

<b>LTE modul</b>	
GPRS/EDGE parameters	EDGE bit rate 237 kbps (DL) / 237 kbps* (UL) GPRS bit rate 85.6 kbps (DL) / 85.6 kbps* (UL) Multislot class 12, CS 1 to 4, 3GPP rel. 99/4 standard
Support channels	Quad band LTE: 800/900/1800/2600 MHz Tri band UMTS (WCDMA): 900/1800/2100 MHz Dual Band GSM/GPRS/EDGE: 900/1800 MHz

Table 14: Technical parameters of module

\* Depending on the capabilities of the operator

### 7.3 Technical parameters of GPS

<b>GPS specifications</b>	
Antenna	50 Ohms – active, passive
Protocols	NMEA 0183 v3.0
Frequency	1575.42 MHz
Sensitivity	Tracking: -161 dBm* Acquisition (Assisted): -158 dBm** Acquisition (Standalone): -145 dBm**
Acquisition time	Hot start: 1 s Warm start: 29 s Cold start: 32 s
Accuracy	Horizontal: < 2m (50 %); < 5 m (90 %) Altitude: < 4 m (50 %); < 8 m (90 %) Velocity: < 0.2 m/s

Table 15: Technical parameters of GPS

\* Tracking sensitivity is the lowest GPS signal level for which the device can still detect an in-view satellite 98 % of the time when in sequential tracking mode.

\*\* Acquisition sensitivity is the lowest GPS signal level for which the device can still detect an in-view satellite 50 % of the time.

## 7.4 Technical parameters of processor

<b>32b ARM mikroprocesor</b>	
Memory	512 Mb DDR SDRAM 128 Mb FLASH 1 Mb MRAM
Interface	Serial interface RS232 Ethernet interface 10/100 Mbit/s USB 2.0 interface

Table 16: Technical parameters of processor

## 7.5 Technical parameters I/O port

<b>32b ARM mikroprocesor</b>		
Input/Output	Binary input Binary output	Reed contact with trigger level 1,3 up to 1,4 V 100 mA / max. 30 V

Table 17: Technical parameters I/O port

## 7.6 Technical parameters of expansion port

Technical parameters of the expansion ports are specified in separate manuals for expansion ports.

## 8. Recommended literature

- [1] Conel: **Start guide,**
- [2] Conel: **Configuration manual,**
- [3] Conel: **User's manual – Expansion port RS232,**
- [4] Conel: **User's manual – Expansion port RS485/RS422,**
- [5] Conel: **User's manual – Expansion port MBUS,**
- [6] Conel: **User's manual – Expansion port CNT,**
- [7] Conel: **User's manual – Expansion port ETH,**
- [8] Conel: **User's manual – Expansion port SWITCH,**
- [9] Conel: **User's manual – Expansion port WIFI,**
- [10] Conel: **User's manual – Expansion port WMBUS,**
- [11] Conel: **User's manual – Expansion port SD,**
- [12] Conel: **Application guide – Expansion port mounting,**
- [13] Conel: **Application guide – Programmer guide.**

## 9. Possible problems



Some network cards are able to be set in situation, when it is not possible to connect the router. It is possible to solve this problem in the following steps:

- hand by selection communication rates 10 MB/s in property network cards,
- connect router over switch,
- start computer only after finalizing the start of the router.

## 10. FAQ

🔗 I can't get from internet on equipment, which is connected to router and I have NAT enabled.

- *The device's gateway has to be configured as the router.*

🔗 Router resets itself, connection on Ethernet fails.

- *It is necessary to use an antenna, which will be situated far from power supply.*

🔗 I don't get on web server at NAT.

- *The remote http access of the router has to be disabled, default server address has to be your web server and the gateway of the web server has to be the IP of router.*

🔗 PPP connection fails.

- *Check signal power. If signal power is weak, you will have to use a better antenna. If the environmental cells have a similar signal it will be necessary to use a directive antenna. Signal levels have to be in the range -50 dBm and -90 dBm.*
- *It is necessary to set ping, which will check the connection and, in the case of fail ping, restart connection.*

🔗 PPP connection won't be established.

- *Recheck GPRS settings - APN, name, password and IP address.*
- *Try to enter PIN – verification if the SIM card hasn't set PIN code.*
- *In private APN it is appropriate to switch the DNS server send off.*
- *Switch log system on and observe where the error turns up.*

🔗 Connection fails on Ethernet or connection isn't establishing.

- *On ethernet interface of the router it is possible to switch auto negotiation off and set a rate and duplex by hand.*

🔗 DynDNS not function.

- *In private APN not functional.*
- *If the same IP address is recorded in your canonic name as dynamically assign address, it means that the operator is using NAT or firewall.*
- *NAT is possible to verify by the help of the ping on address of your server with static IP address and by the help of the router address verify and address in ping.*
- *Firewall is possible to verify, for example by remote access on web interface.*

- *The operator doesn't give out address DNS servers and without DNS server's it is impossible to connect to server dyndns.org. In log system will be this message:*
  - *DynDNS daemon started*
  - *Error resolving hostname: no such file or directory*
  - *Connect to DynDNS server failed*
  
- 📄 IPsec tunnel is establishing but communication doesn't function.
  - *Probably it is badly set up route conditionals of connected equipment or it is bad set up GW.*
  
- 📄 FTP doesn't function.
  - *Router doesn't support the active FTP mode, supports the passive mode only.*
  
- 📄 RS232 doesn't function.
  - *It is necessary to verify present the expansion port RS232.*
  - *Verify present the expansion port RS232 in router configuration in menu „external port“, or verify connection locally by the help Telnet-Hyper terminal.*
  
- 📄 L2TP or IPsec isn't establishing.
  - *Verify the reason in the log system.*
  
- 📄 I switched the router to offline mode by the SMS message, but the router is in online mode after restart.
  - *Control SMS messages don't change the router configuration. For example, if the router is switched to offline mode by SMS message the router will be in this mode up to next restart. This behaviour is the same for next all control SMS messages.*

# 11. Customers Support

You can find current information about this product on our website:

[www.conel.com](http://www.conel.com)



## Upkeep-advice:

- The SIM-card must be handled carefully as with a credit card. Don't bend, don't scratch on this and do not expose to static electricity.
- During cleaning of the router do not use aggressive chemicals, solvents and abrasive cleaners!

Conel Company hereby declares that the router narrated in this user's guide fits all basic demands of directive 1999/5/EC (R&TTE).

Router fits values of coefficient SAR defined by association ICNIRP and values of "About protection of health before non-ionized radiation".



Declaration of conformity was issued and it is possible to find it on the Conel website (<http://www.conel.com/download>)<sup>1</sup> or at producer.

---

<sup>1</sup>Please, use the following login information: Username – ConelFreeDownload, Password – coneldownload.